

AVERY DENNISON MARKETING SPECIFICATION

HISTORY

REV.	DATE	DESCRIPTION
A	01.15.16	RELEASED

THE SUBJECT MATTER DISCLOSED HEREIN EMBODIES PROPRIETARY INFORMATION WHICH IS THE CONFIDENTIAL PROPERTY OF THE AVERY DENNISON CO. NONE OF WHICH SHALL BE COPIED, REPRODUCED, DISCLOSED TO OTHERS, PUBLISHED OR USED IN WHOLE OR IN PART, FOR ANY PURPOSE OTHER THAN THAT FOR WHICH IT IS BEING MADE AVAILABLE WITHOUT THE EXPRESS ADVANCE WRITTEN PERMISSION OF A DULY AUTHORIZED AGENT OF THE COMPANY. THIS DOCUMENT IS THE PROPERTY OF THE AVERY DENNISON CO. AND IS TO BE RETURNED TO THE COMPANY ON DEMAND.

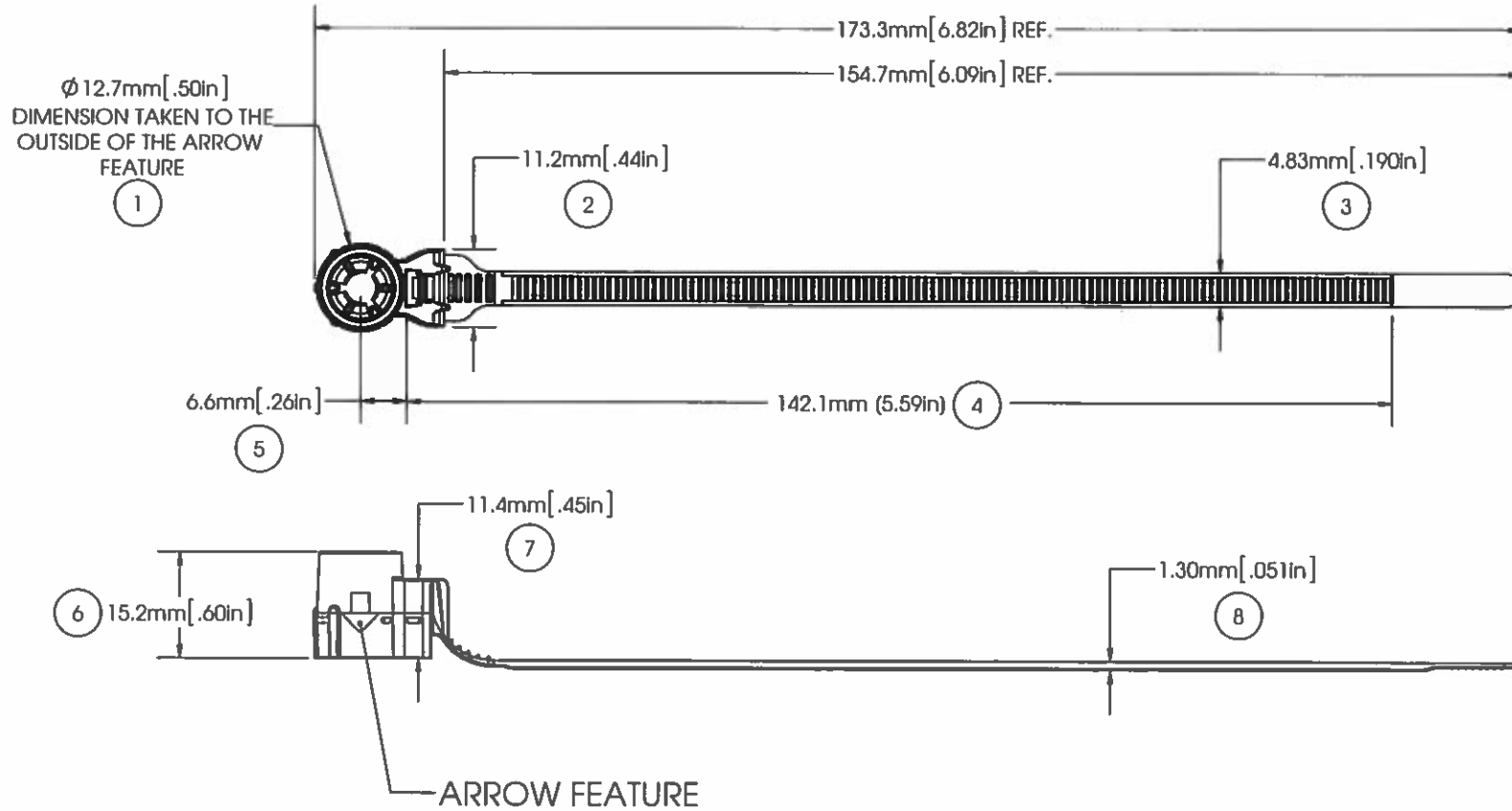

MOUNTING:	M5 and M6 STUD
TENSILE STRENGTH:	50 LBF / 222N MIN.
WEIGHT:	2.19g
TEMPERATURE RANGE:	-40°F (-40°C) TO 302°F (150°C) CONTINUOUS AND 329°F (165°C) AT MAXIMUM EXPOSURE
BUNDLE DIAMETER:	Ø1.6mm TO Ø38.1mm
TOOL:	12001- HAND INSTALLATION TOOL 12500- PNUM. INSTALLATION TOOL
TOOL TENSION SETTING:	6 - 8
PACKAGING:	1000/BAG, 5 BAGS/MASTER

APPROVALS: ENG. APPR. *[Signature]* 1/26/16
Q.A. APPR. *[Signature]* 1/26/16

AVERY DENNISON
FASTENER DIVISION
FITCHBURG, MA 01420 U.S.A.
TEL. 1-800-225-5913
FAX. 978-353-8157

SPECIFIED TOLERANCES ARE:	
.XX ± .03 INCHES	.X ± .7 mm
.XXX ± .010 INCHES	.XX ± .25 mm
ANGULAR: ± 2°	

MATERIAL	NYLON 6/6, IMPACT MODIFIED, HEAT STABILIZED
COLOR	BROWN
DESCRIPTION	M5/M6 COMPACT WELD STUD TIE, HI HEAT
STOCK NO.	20146-HHBN
REV.	A